

# **PERI-PRO<sup>®</sup>**

## **X-RAY FILM PROCESSOR**

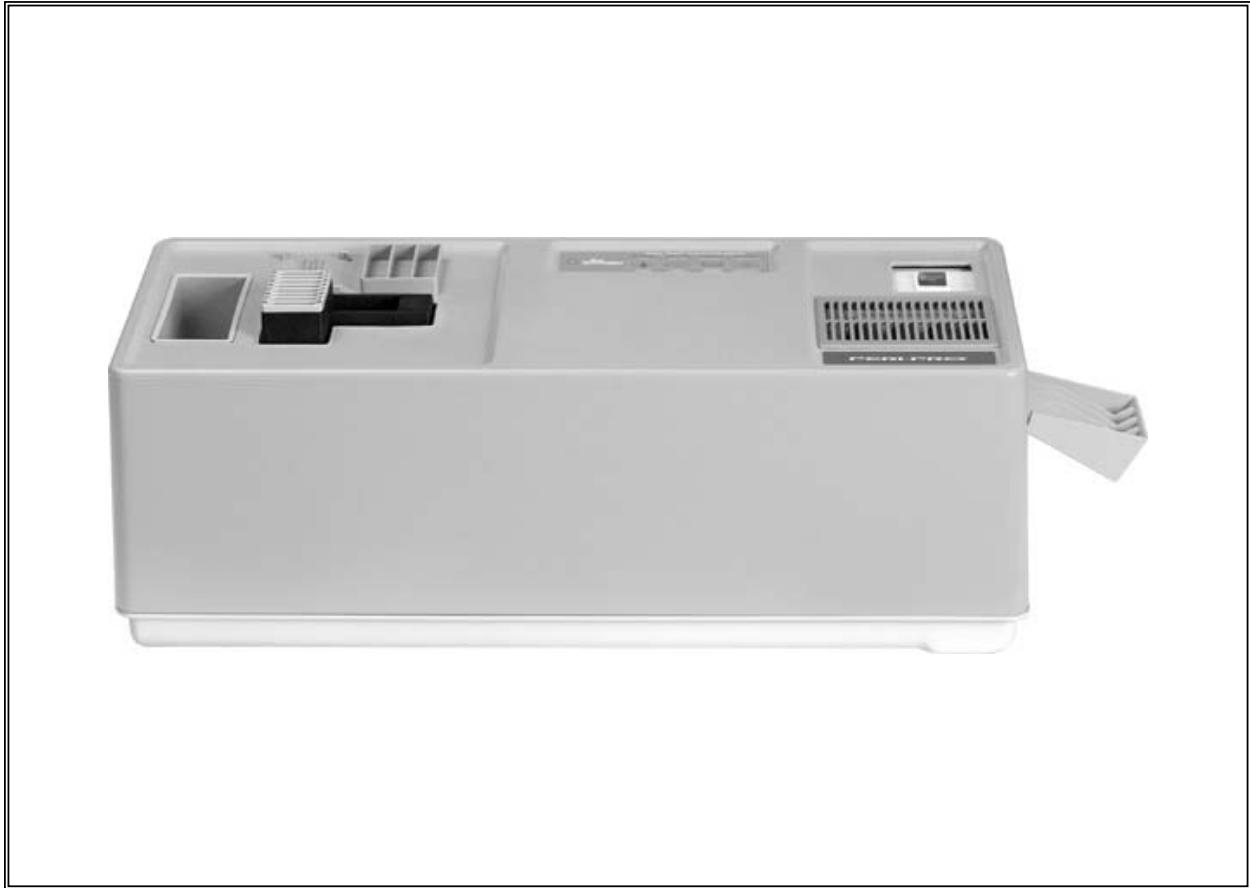

## ***USER'S MANUAL***

# **INTRODUCTION**

---

Your new Peri-Pro X-Ray Film Processor delivers fully-processed, dry intraoral radiographs. It is easy to operate and maintain. This manual provides the information to insure successful results.

Peri-Pro Developer and Fixer solutions (P/N 90800) have been specially formulated for use in the Peri-Pro. Use no other chemistry in your machine. A case of chemistry, good for 3 fillings, has been provided with your processor.

Please take the time to read this manual before using your Peri-Pro and keep it handy for future reference.

## **TABLE OF CONTENTS**

---

<b>Section</b>		<b>Page</b>
1	Specifications . . . . .	3
2	Installation and Preparation . . . . .	4
3	Processing . . . . .	5
4	Helpful Hints in Using the Peri-Pro . . . . .	7
5	Water Change and Cleaning . . . . .	8
6	Chemistry Change . . . . .	9
7	Film Problems . . . . .	10
8	Machine Problems . . . . .	13
9	Realigning the Drive Arms . . . . .	14
10	Cleaning the Shutter . . . . .	15

# SECTION 1 : SPECIFICATIONS

## OVERALL DIMENSIONS

- ❑ **Dimensions:**
  - 25" Long; 9 3/4" Wide; 8 1/2" High.
  - With Daylight Loader: 25" Long; 9 3/4" Wide; 15 3/4" High.
  - With Film Duplicator/Daylight Loader: 25" Long; 12 3/4" Wide; 15 3/4" High. (Add 3 1/2" to length for film receptacle)
- ❑ **Minimum Clearance to Remove Cover:**
  - Without Daylight Loader: 14 1/2"
  - With Daylight Loader or Film Duplicator/Daylight Loader: 21 3/4"
- ❑ **Tank Capacities:**
  - Developer and Fixer Tanks: 1 Quart Each
  - Wash Tank: 1 1/2 Quarts
- ❑ **Electrical Requirements:** 115 Volts, 5 Amps
- ❑ **Plumbing:** None
- ❑ **Weight:** 27 pounds - Peri-Pro

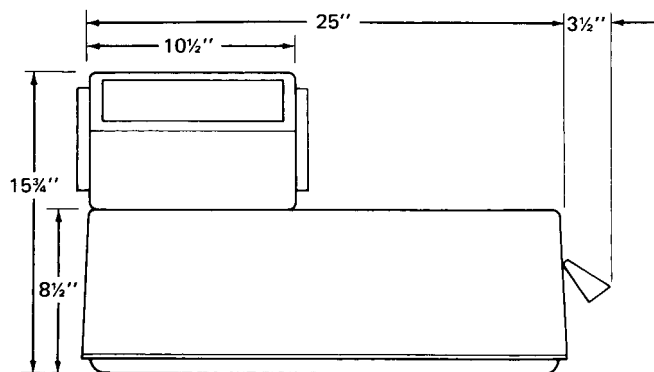

Peri-Pro X-Ray Film Processor Outline  
Dimension View  
(Shown with Optional Daylight Loader:)

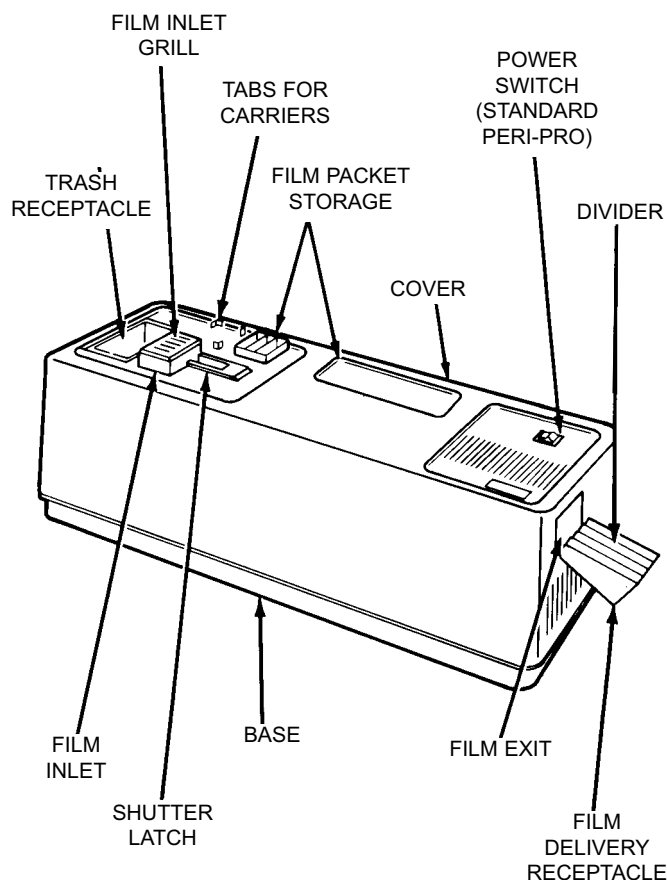

Peri-Pro X-Ray Film Processor  
Component/Control Location

## **SECTION 2: INSTALLATION AND PREPARATION**

---

### **UNPACK THE PERI-PRO. CLEAN UNIT OF ALL PACKING MATERIAL.**

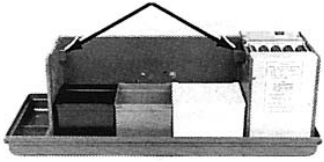

2.1  
Set the base on a level surface.  
Be sure surface is stable so chemistry does not splash or spill.

**Note:** The three tanks are:  
Black for developer (left)  
Red for fixer (center)  
White for water (right).

2.2  
Use room temperature tap water and fill the white water tank up to the fill level indicator line.

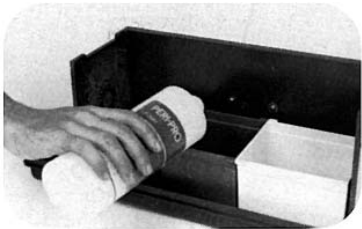

2.3  
Remove black tank to prevent contamination of developer.  
Fill the red fixer tank with the entire contents of the red bottle of Peri-Pro Fixer to the marked interior fill level indicator lines.  
Be sure it is at room temperature (70 - 82°F). Pour carefully to prevent splashing.  
Reinsert the black tank and fill it with the black bottle of Peri-Pro Developer to the marked interior fill level indicator lines. Be sure its temperature is between 70 - 82°F.

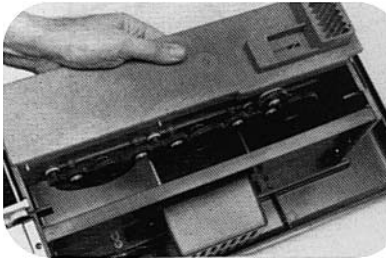

2.4  
To insert the transport, place its back against the two tabs on the vertical plates (shown in 2.1).  
Carefully lower into place.

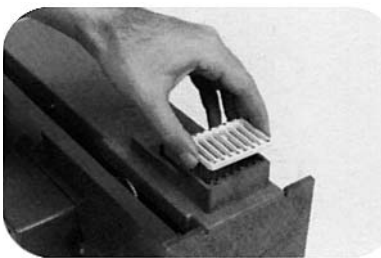

2.5  
Be sure that the transport sits squarely in the cutouts on top of the vertical plates.  
The right side of the transport rests on the dryer transport.  
Insert the inlet grill. Note that it goes in one way only.

### **INSTALL COVER**



2.6  
Install the cover and put the film receptacle into the exit of the cover by hooking the lip of the receptacle into the opening as shown. When removing the cover, be sure to first remove this receptacle.

2.7  
Plug the line cord into a 115 V outlet.

## YOU ARE NOW READY TO PROCESS FILM

Expose a film at your normal x-ray setting. Follow directions to process the film. Duplicating films exposed in the Peri-Pro Film Duplicator/Daylight Loader are processed the same manner as described below.

### 3.1

Depress Power Switch. Peri-Pro is now operating. X-Rays may now be processed.



### 3.2

Strip a film and place it into any of slots 1-8 with dimple side up. Load all 8 slots if necessary.

Never put two films into the same slot.

- If a film is bent, straighten it.
- If the film has a burr or rough edge, load this edge facing up.
- After stripping a film, deposit the packet into the trash box.



### 3.3

Slide shutter latch to the right to the stop.

**Note:** If shutter does not catch wait a few seconds and repeat.

Note that films do not drop at this time. They will drop when the machine automatically moves the shutter fully open. This may take 5 to 40 seconds.

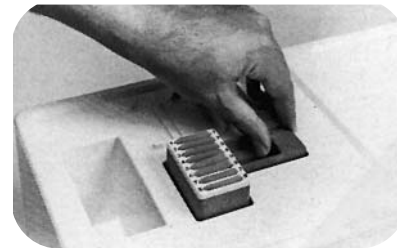

### 3.4

As soon as the shutter closes, you may load the next group of films and repeat steps 3.2 and 3.3.

When last films are loaded, place the inlet cover (See photo in para 3.7) over inlet. If using daylight loader, install the inlet cover before removing hands from cuffs.

### 3.5

The films are delivered in the receptacle, ready to be mounted. Note (when dividers are in place) the four compartments in the receptacle. They correspond to slots 1 & 2, 3 & 4, 5 & 6, 7 & 8, in the inlet grill. You may use these pairs of tracks to separate sets of film.

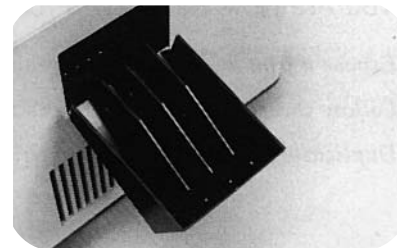

## PROCESSING SIZE #0 (PEDO), SIZE#1 (ANTERIOR), SIZE #3 (BITEWING) AND #4 (OCCLUSAL) FILM:

### 3.6

Size #2 film can be fed directly into the processor. Sizes #0, #1, #3 and #4 are transported in film carriages (shown right), which are supplied with the processor. Paragraphs 3-7, 3-8 and 3-9 provide processing procedures. When using film carriages, make sure that the it is not bent. A damaged carriage could cause film transport problems. Always shutdown the Peri-Pro when not processing film by placing the Power switch in the OFF position.



## SECTION 3: PROCESSING

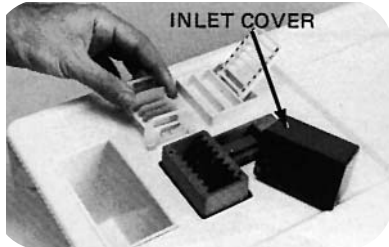

### 3.7 Size #0 and #1 Films

- To load #0 or #1 film into the corresponding # carrier, nest the carrier inside the tabs on the cover, next to the inlet grill.
- Strip the cover off the film(s) and slide the film(s) vertically, one at a time, into any of the six grooves on the carrier. Push down firmly until the film touches the cover. Repeat until as many grooves as required are filled. The films should be standing vertically and parallel to each other, away from the centerbar. Make sure that each film on the carrier is in its own groove.
- Remove the film inlet grill. (Remember to replace it when processing #2 films.) Insert the carrier, with the film(s) standing vertically, into the film inlet. Be sure films are centered in the grooves.
- Slide the shutter to the right until it latches. The carrier will drop into the transport and begin processing when the shutter automatically opens.

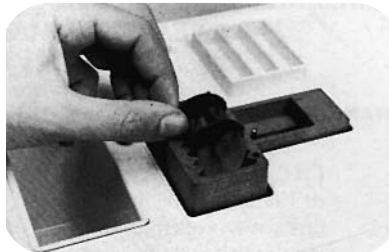
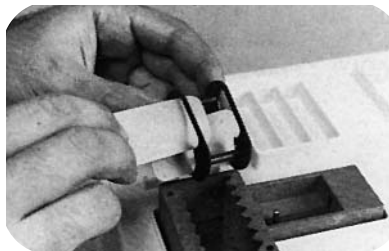

**Note:** Make sure that the carriage is not bent. A damaged carriage could cause film transport problems.

### 3.8 Size #3 Films

- Strip the cover off one or two #3 film(s) and slide the film(s) horizontally, one at a time, through both side plates of the #3 carrier. Remove film inlet grill.
- Insert the carrier into slots 3 and 6 in the film inlet. Make sure the edges of the film(s) clear the side walls of the film inlet.
- Slide the shutter to the right until it latches. The carrier will drop into the transport and begin processing when the shutter automatically opens.

### 3.9 Size #4 Films

- Strip the cover off one #4 film and carefully bend almost in half. Slide the film into the carrier, making sure both edges of the film are held in place by the guide tabs. Remove film inlet grill.
- Place the carrier onto the film inlet with the orientation arrow (on the side of the carrier) pointing down.
- Slide the shutter to the right until it latches. The carrier will drop into the transport and begin processing when the shutter automatically opens.

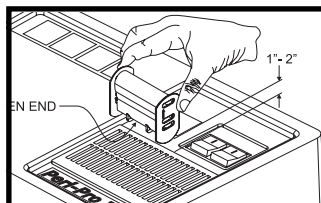
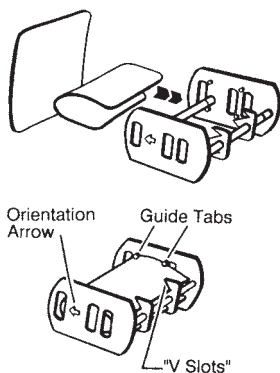

**A manual assist may be needed to assure complete drying of processed # 4 films**

- While the fan is blowing, hold the open end of the film in the carrier 1 to 2 inches directly over the dryer grille and slowly pivot the carrier to have warm air blow on the outer surface.
- 30 to 60 seconds should be enough time to adequately dry film.
- Unload the dried film from the carrier when done.

## **SECTION 4: HELPFUL HINTS IN USING THE PERI-PRO**

### **1. Recommended Chemistry Water Change**

- Change water every day.
- Change chemistry every 300-350 films or in two weeks, whichever is sooner.
- Place the calendar date of the most recent change and the next change date in a conspicuous location. Update the entry when you change the water and the chemistry.

- Be sure to follow this schedule - Although X-rays processed beyond this schedule may appear satisfactory today, they may not have the storage life you expect.
- When processing films with the Peri-Pro, follow the temperature guidelines in paragraph 3 below.
- Having a good routine from the beginning will insure that this schedule is followed. Keeping the chemistry and water fresh will result in consistent film quality and minimum x-ray exposure to your patients.

### **2. Liquid Levels**

- Change water every day.
- Frequently check the liquid levels in the three tanks. If necessary, top off the two chemistry tanks to the recess line with distilled water.
- Low liquid levels may cause an artifact to appear on the film. See Section 7 Problem 6.

### **3. Chemistry Temperature**

- The Peri-Pro has been designed to give optimal results with the temperature of the Peri-Pro Developer and Fixer chemistry in the range of 70° - 82°F. If the temperature of the chemistry is not within this range when you fill the tanks, wait until it reaches room temperature before processing. If the room temperature is below 70° F, keep the switch on to raise the chemistry temperature above 70°F. Once the proper temperature is achieved, be sure to shut-off the Peri-Pro by depressing the Power Switch.

### **4. Operational Quality Test**

A. Check the quality of processed films, as follows:

1. Turn on the Peri-Pro by depressing the Power Switch
  - a. make sure that the chemistry temperature is between 70°-82°F.
  - b. Wait for the Ready Light to illuminate.
2. Process an unexposed film.
3. Momentarily expose a film to room light and then process.
4. The unexposed film should be completely clear.
5. The light exposed film should be completely black.
6. If your results differ from (4) and (5), consult the troubleshooting section.

B. Check the consistency of processed films, as follows:

1. After cleaning the processor and refilling with fresh chemistry, process a double film packet that has been exposed as part of a regular x-ray examination.
2. Make sure that the chemistry temperature is between 70° - 82°F.
3. Mount one of these films in the corner of your view box, and retain it as an index film.
4. Periodically, place a film next to this index film for comparison purposes. Be certain this film has been exposed using the identical technique factors as the index film.
5. Compare the density and clarity of the two films.
6. Consult the troubleshooting section should any major differences occur.

## SECTION 5: WATER CHANGE AND CLEANING

---

**REMBER: CHANGE THE WATER EVERY DAY. TOP OFF THE CHEMISTRY TANKS TO THE RECESS WITH WATER.**

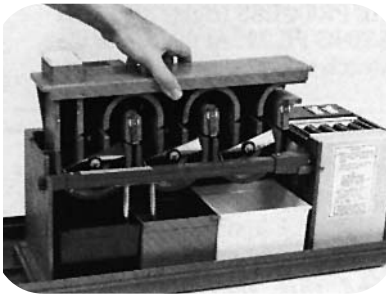

5.1 Remove the power cord from the outlet. Remove the film receptacle and the cover. Lift transport and hold for a few seconds over the tanks so liquids drain back into tanks. Do not splash or chemistry contamination may result.

5.2 Carefully place transport on service tray.

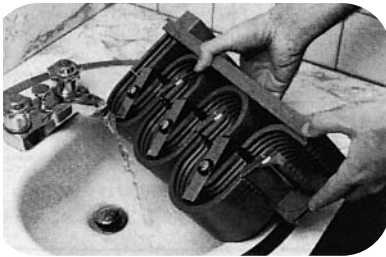
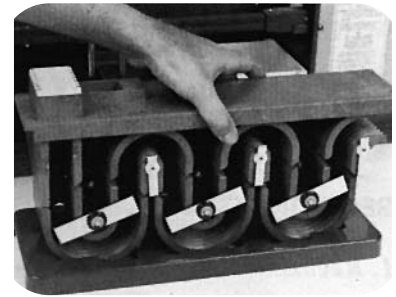

5.3 Rinse transport thoroughly with warm water to soften residue and dried chemistry. Be sure to rinse just above the chemistry line, also, where buildup occurs. Keep film inlet and shutter area dry.

5.4 Scrub the grooves with a toothbrush, particularly just above the chemistry line. Rinse grooves again to remove these deposits. Scrub and rinse gears at rear of transport.

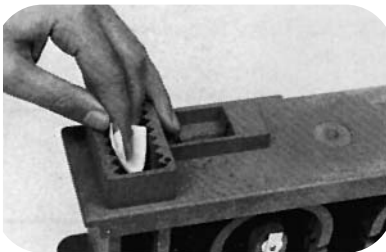
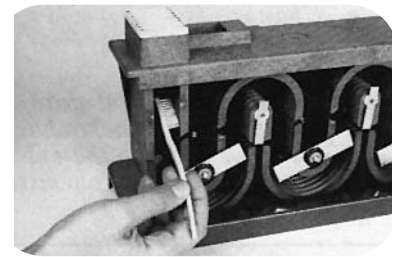

5.5 With a dry or slightly moist, lint-free cloth, wipe off the shutter and the inlet grid. Before processing, be sure the shutter and the inlet area are dry.

5.6 Remove the water tank, discard the water and rinse out the tank. Note that the service tray is designed to hold all tanks safely. Refill the water tank with 70° 80°F water; reinsert into base.

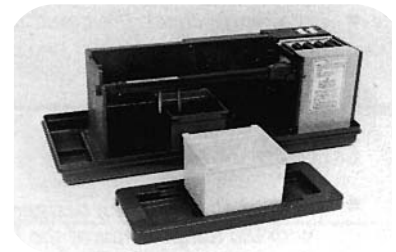

5.7 If the chemistry is two weeks old, or 300-350 films have been processed, the chemistry must also be changed. See Section 6.

5.8 If the chemistry does not require changing, top off the developer and fixer tanks to the recess with water. Reinstall the cover and film receptacle.

THE PERI-PRO TRANSPORT CLEANING KIT (STOCK #43975) PROVIDES A DEEP CLEANING ACTION THAT CAN PROLONG THE LIFE OF YOUR TRANSPORT WHEN USED AT LEAST TWICE A YEAR. THE KIT WILL CLEAN AREAS THAT A BRUSH ALONE CANNOT REACH.



## SECTION 6: CHEMISTRY CHANGE

**REMBER: CHANGE THE WATER EVERY DAY. TOP OFF THE CHEMISTRY TANKS TO THE FILL LINES WITH DISTILLED WATER.**

**NOTE:** Repeat steps of 5.1 and 5.2 before proceeding.

6.1

Change the water. Remove the developer and fixer tanks and dispose of in accordance with applicable environmental protection laws. Rinse and sponge the tanks and reinsert the fixer tank only into the base.

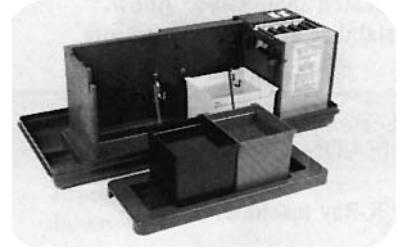

**Note:** Do not over fill tanks. Fill the Fixer and Developer tanks only up to the marked interior fill level indicator lines.

6.2

Carefully pour the entire contents of the bottle of Peri-Pro fixer into the fixer tank (red). Reinstall the Developer (black) tank and fill it with Peri -Pro Developer

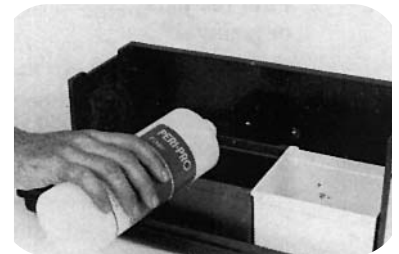

6.3

Carefully reinsert the transport by placing the back of the transport against the two tabs on the vertical plates. Slowly lower into place..



6.5

Re-install the cover and the film receptacle.

6.6

Plug the line cord into the outlet.



## **SECTION 7: FILM PROBLEMS**

---

<b>Problem</b>	<b>Probable Cause</b>	<b>Correction</b>
<b>1. Film too light</b>	a. Developer exhausted.	a. Change chemistry after 300 - 350 films or 2 weeks, whichever is sooner.
	b. Developer temperature below 70°F.	b. Keep processor on and wait until developer temperature is at least 70°F.
	c. X-Ray machine improperly set or inconsistent.	c. Adjust or repair X-Ray machine.
	d. Developer contaminated.	d. Replace chemistry. Pour carefully.
	e. Improper or outdated film.	e. Check date on film box.
	f. Not using Peri-Pro Chemistry.	f. Use Peri-Pro Chemistry.
<b>2. Film too dark or grainy</b>	a. Developer temperature too high.	a. Allow temperature to stabilize at room temperature (70 - 82°F).
	b. X-Ray machine improperly set or inconsistent.	b. Adjust or repair X-Ray machine.
	c. Film exposed to light	c. Check for and correct light leak in dark room or daylight loader. Use inlet cover on film inlet before leaving darkroom or removing hands from daylight loader cuffs.
	d. Not using Peri-Pro Chemistry.	d. Use Peri-Pro Chemistry.
<b>3. Film is cloudy or has brownish surface</b>	a. Fixer exhausted.	a. Change chemistry after 300 - 350 films or 2 weeks, whichever is sooner.
	b. Fixer temperature below 70°F.	b. Keep processor on and wait until fixer temperature is at least 70°F.
	c. Improper or outdated film.	c. Check date on film box and use film recommended for automatic processing.

---

## SECTION 7: FILM PROBLEMS

Problem	Probable Cause	Correction
4. Film is not dry	a. Improper or outdated film.	a. Check date on film box and use film recommended for automatic processing
	b. Depleted chemistry.	b. Change chemistry after 300 - 350 films or 2 weeks, whichever is sooner.
	c. Contaminated chemistry.	c. Replace chemistry. Pour carefully.
	d. Not using Peri-Pro Chemistry	d. Use Peri-Pro Chemistry.
	e. Defective dryer heater, fan motor or thermal fuse. (If air is not hot, heater or fuse is defective.)	e. After 7 minutes, dryer heater outlet temperature should be 140°-155°F. If not, replace heater, motor or thermal fuse. (See photo.) All three are connected by push-on tabs. Remove tabs (and mounting screws for heater and motor) to replace defective component.

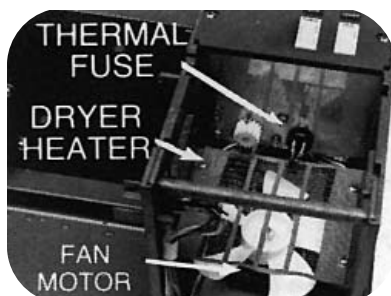

Never work on live circuits. Voltages within the unit may be of sufficient magnitude to cause electric shock. Make sure to unplug the line cord from the electrical source before proceeding.

5. Film has black edge at one end	a. Light fog	a. Cover film inlet with the inlet cover before edge at one end opening darkroom door or removing hands from daylight loader.
	b. Light fog	b. Safe light defective or too close (should be minimum of 4 feet away from work area).
	c. Light fog	c. Light leak in dark room or daylight loader.

## SECTION 7: FILM PROBLEMS

---

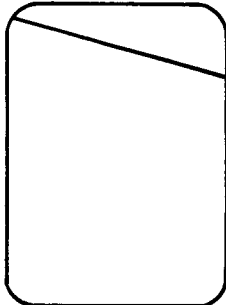
Problem	Probable Cause	Correction
<p>6. Film has diagonal or curved line through it, as shown.</p> 	<p>a. Chemistry level is low (entire film not being covered)</p> <p>b. Transport has deposits in grooves keeping films from fully dropping into chemistry bath.</p> <p>c. Timing is out of adjustment.</p>	<p>a. Top off tank to the fill level indicator lines with distilled water.</p> <p>b. Use toothbrush to clean out grooves. (See paragraphs 5.1 - 5.4, page 8).</p> <p>c. See Section 9.</p>

---

<p>7. Images of other films appear on films. (Light striking films that were stripped and stacked on each other before loading.)</p>	<p>a. In dark room, safelight is defective or less than 4 feet from inlet.</p> <p>b. Light leak through dark room door.</p> <p>c. With daylight loader, too much light is passing through the amber loader.view glass.</p>	<p>a. Correct as required.</p> <p>b. Correct as required.</p> <p>c. Test by covering amber view glass of daylight. If this corrects the problem, adjust lighting, relocate machine or install red view glass (PIN 90780).</p>
--	--	---

---

## SECTION 8: MACHINE PROBLEMS

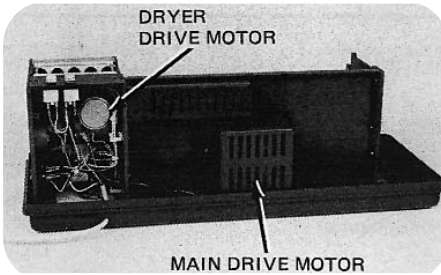
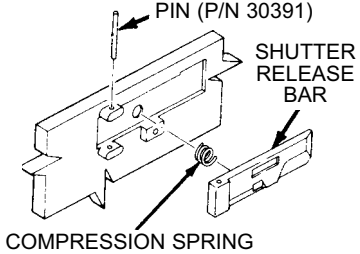
Problem	Probable Cause	Correction
<b>1. Film not exiting</b>	<ul style="list-style-type: none"> <li>a. Chemistry deposits in groove of transport cause film to pop out.</li> <li>b. Severely bent or jagged film.</li> <li>c. Films fed incorrectly.</li> <li>d. Arms out of alignment. (Lost film will be constant not occasional.)</li> <li>e. Defective main or dryer motor. (See photo below.)</li> </ul>	<ul style="list-style-type: none"> <li>a. Clean grooves. See paragraphs 5.1 - 5.4, page 8 of this manual.</li> <li>b. Straighten film before loading. Put rough or burred end in last.</li> <li>c. Seat transport squarely (see Para. 2.4). Put only one film into a track. (See Para. 3.3.) Load carriage so film does not hit side of inlet. Use film inlet grille for # 2 film.</li> <li>d. See Section 9.</li> <li>e. Replace motor.</li> </ul>
		
<b>2. Shutter will not catch even after several tries.</b>	<ul style="list-style-type: none"> <li>a. Broken Compression Spring (PIN 90545).</li> <li>b. Worn Shutter release bar (PIN 90548)</li> <li>c. Defective Shutter (PIN 90510)</li> </ul>	<ul style="list-style-type: none"> <li>a. Replace Compression Spring. See Sketch.</li> <li>b. Replace shutter release bar. See Sketch.</li> <li>c. Replace shutter - see Section 10.</li> </ul>
		
<b>3. Shutter sticks or is hard to move.</b>	<ul style="list-style-type: none"> <li>a. Shutter contaminated with chemistry.</li> <li>b. Broken shutter return spring (PIN 90512).</li> <li>c. Shutter is off its tracks.</li> </ul>	<ul style="list-style-type: none"> <li>a. Clean shutter with dry or slightly moist, lint-free cloth. See Section 10 for further cleaning instructions, if required.</li> <li>b. Replace shutter return spring. See Sketch, Section 10.</li> <li>c. Reassemble shutter. See Section 10, page 15 ).</li> </ul>
<b>4. Processor not working.</b>	<ul style="list-style-type: none"> <li>a. Line cord not plugged in.</li> <li>b. Defective fuse.</li> <li>c. Defective switch.</li> </ul>	<ul style="list-style-type: none"> <li>a. Plug in line cord.</li> <li>b. Replace fuse (PIN 90232). (Remove cover. Fuse on right side, 5 AMP 115V)</li> <li>c. Replace Switch.</li> </ul>

## SECTION 9: REALIGNING THE DRIVER ARMS

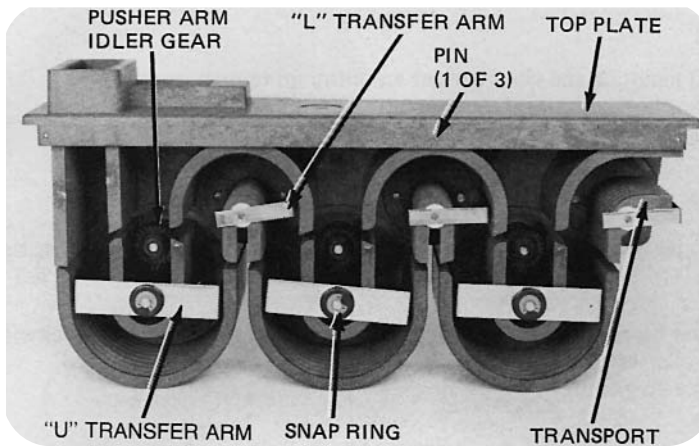

Figure 1.

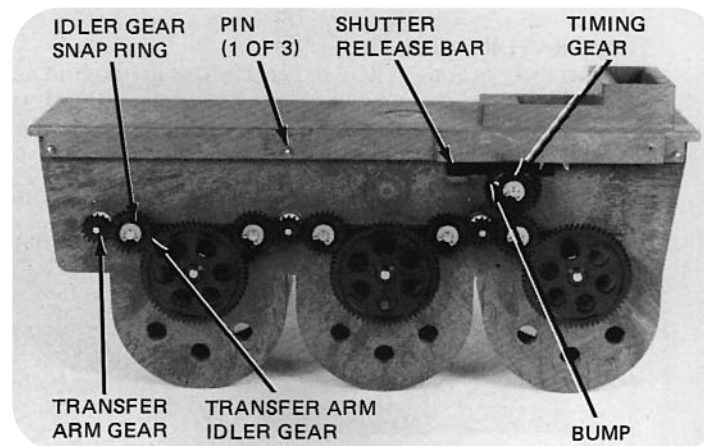

Figure 2.

The position of the six driver arms, relative to the timing gear (Figure 2) on the rear of the transport is important for proper transport of film. Position your transport as shown in Figure 1. The three "U" shaped pusher arms and the three "L" shaped transfer arms are approximately horizontal. With the arms in this position, look at the timing gear (Figure 2). The bump is to the left at approximately 10 o'clock. This orientation should always be maintained: All six arms are horizontal when the bump on the timing gear is to the left at approximately 10 o'clock.

If any arm is out of alignment, it is probably due to broken or chipped teeth in a gear. Check for this and replace the gear. Experience has shown that chipped gears occur in dirty transports so be sure to follow cleaning instructions in Section 5.

If any arm is out of this configuration, correct by following these directions:

A "U" Pusher Arm:

- 1) Remove its snap ring.
- 2) Lift out the arm. Rotate it relative to its idler gear.
- 3) Reinsert arm and install the snap ring.

B "L" Transfer Arm:

- 1) Remove the snap ring on the appropriate transfer arm idler gear. This idler gear is adjacent to the drive gear for the transfer arm.
- 2) Remove this idler gear and rotate the transfer arm gear to the proper orientation.
- 3) Install the transfer arm idler gear and its snap ring.

C Timing Gear:

- 1) Remove the timing gear snap ring.
- 2) Slide off the timing gear.
- 3) Position all arms in the horizontal position (Figure 1).
- 4) Replace the timing gear with the bump to the left at approximately 10 o'clock. Be sure the inside gear fits squarely into the timing gear.
- 5) Install the snap ring.

## SECTION 10: CLEANING THE SHUTTER

If the shutter does not move freely, it must be cleaned.

To remove the shutter:

- A) The top plate is secured to the transport by three pins (Figures 1 & 2 and sketch above).
- B) Tap out all the pins from the rear of the transport (direction of arrow). Pullout with pliers from front of transport lift off top plate and position as in sketch. (Plate upside down with shutter and spring showing.)

Lift off shutter and unhook from spring. Do not stretch spring. If shutter was sticking, rinse shutter under running water. Dry thoroughly with a dry, lint-free cloth. Also, clean inside of top plate and inlet area. Dry thoroughly.

Reassemble, by hooking spring to shutter by placing end of spring into hole in shutter.

Reinsert top plate onto transport. Be sure to depress shutter release bar (Figure 2) when putting top plate on.

Line up three pairs of holes in top plate with three pairs of holes in transport. Test shutter for ease of operation before repinning. If it has been cleaned and dried thoroughly, it will slide smoothly.

Reinsert pins by inserting tapered end first and tapping knurled end in until flush (opposite direction of arrow).

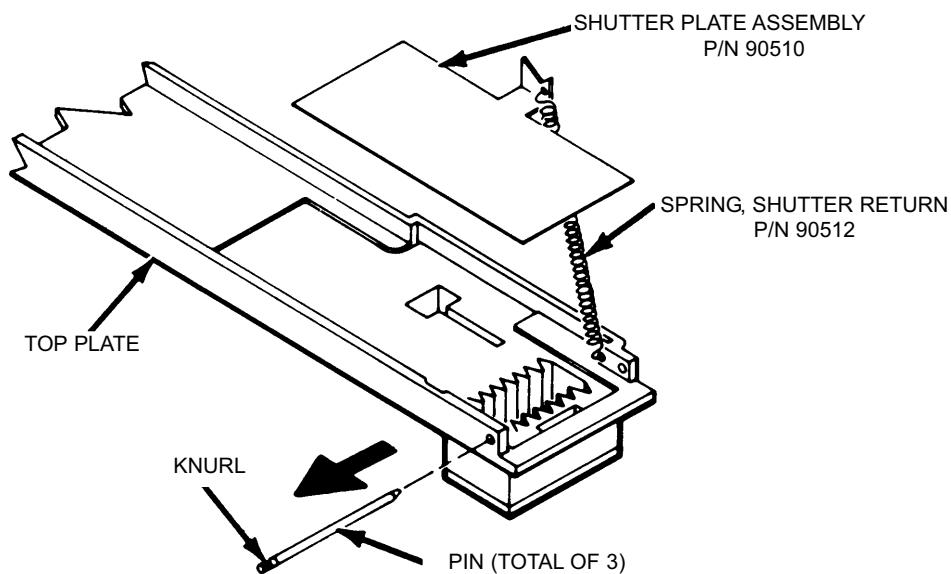

*Air Techniques is a leading manufacturer of fine dental equipment from air and vacuum systems and X-ray film processors, to an impressive line of new products incorporating the most recent technological advances. These new products, vital components of the innovative dental practice, include intraoral cameras, digital imaging systems which utilizes phosphor plate technology or sensor technology and, most recently, an intraoral digital X-ray system.*

*Air Techniques has been manufacturing quality products for the dental and medical professional since 1962.*

- Accent Intraoral Digital X-ray Image System
- Acclaim Intraoral Digital Video Camera System
- AirStar®
- Guardian™ Amalgam Collector
- A/T 2000® XR
- Peri-Pro®
- Provecta 70®
- ScanX®
- STS™
- VacStar™

Air Techniques' products are distributed only through authorized dealers.

**AIR  
TECHNIQUES**  
INC.

1-800-AIR-TECH (1-800-247-8324)

**[www.airtechniques.com](http://www.airtechniques.com)**